

## Open die forging press

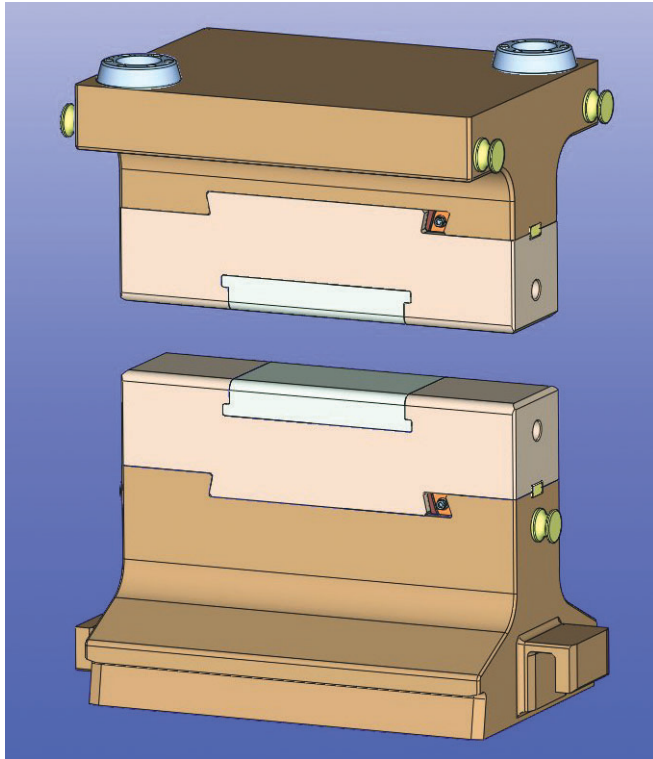

### Open die forging press

Year of construction 2007

Nominal pressing force 50 MN

#### Feuerbacher tensioning key 99.550 FF

Height 99 mm, width 115 mm, length 550 mm

Cup spring package inside

Fully supported vertical contact face

Thread W1"

Angles 12°/20°

## Details of application

For fixing die carriers ranging in depths from **450 to 800 mm**.

Weight of the dies depending on depth of die blocks **approx. 2.500 kg – 4.000 kg**.

In the event of one sided wear the carriers can be turned round through 180°.

The tensioning keys are completely covered by the die.

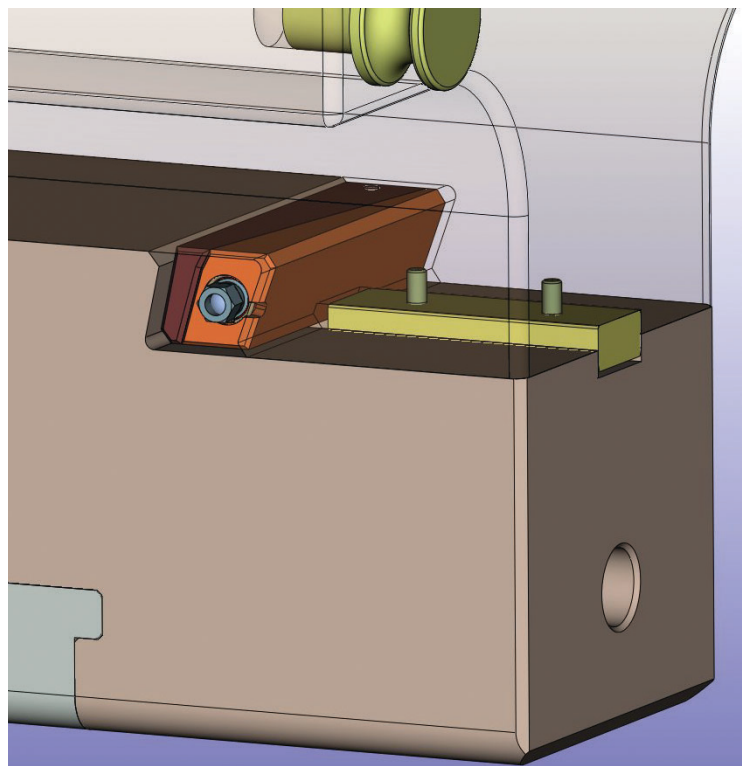

## General

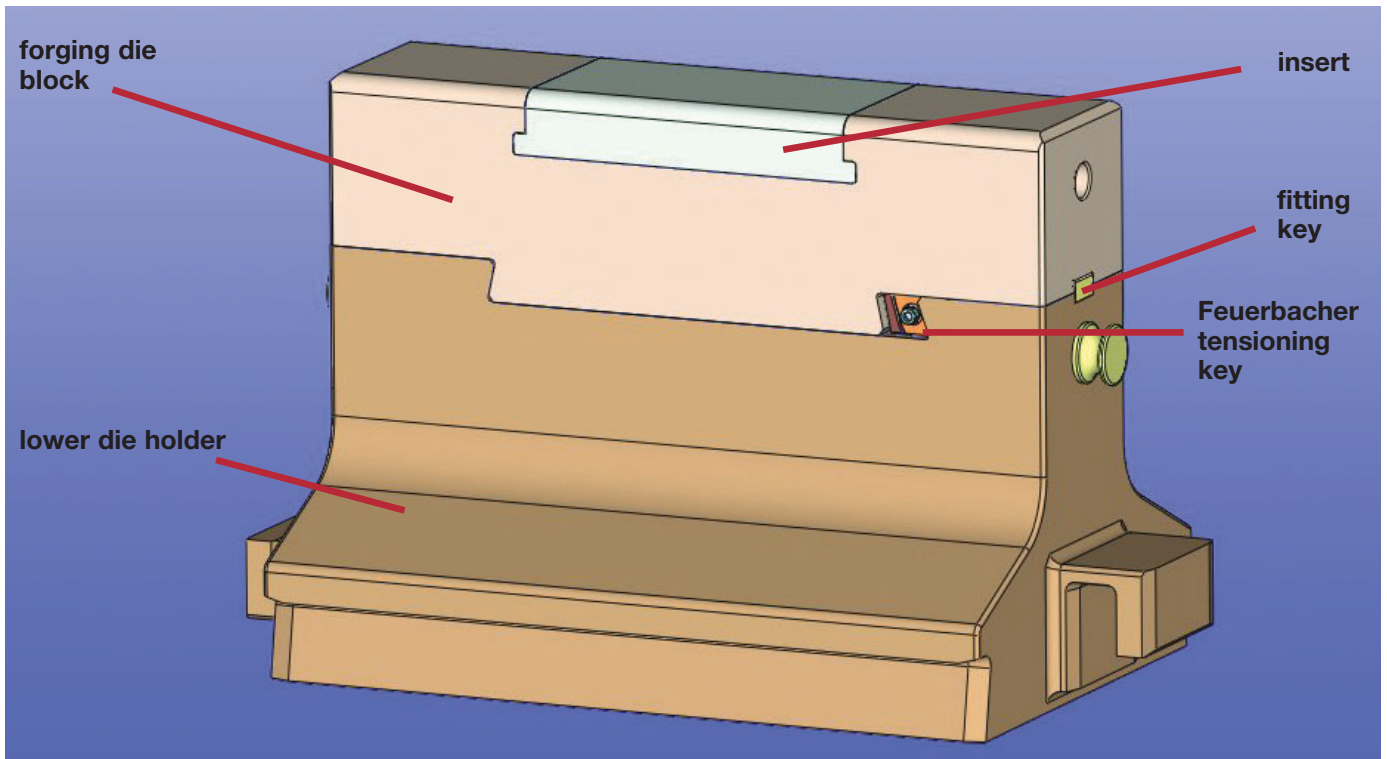

## Alternative arrangement

Die set for cutting a massive steel slab.

The die set can be installed on any die holder by means of a Feuerbacher tensioning key.

